

SR SUNTOUR

V-Boxx FR9

Owner's Manual

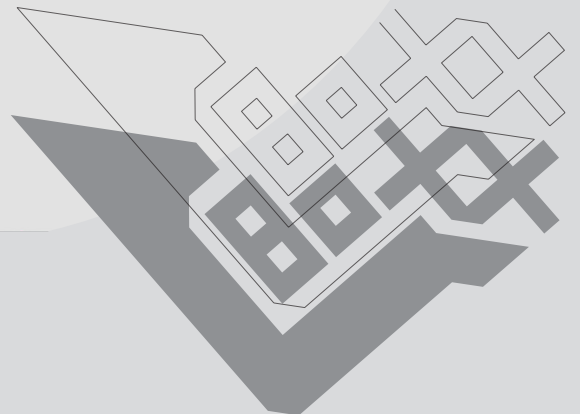

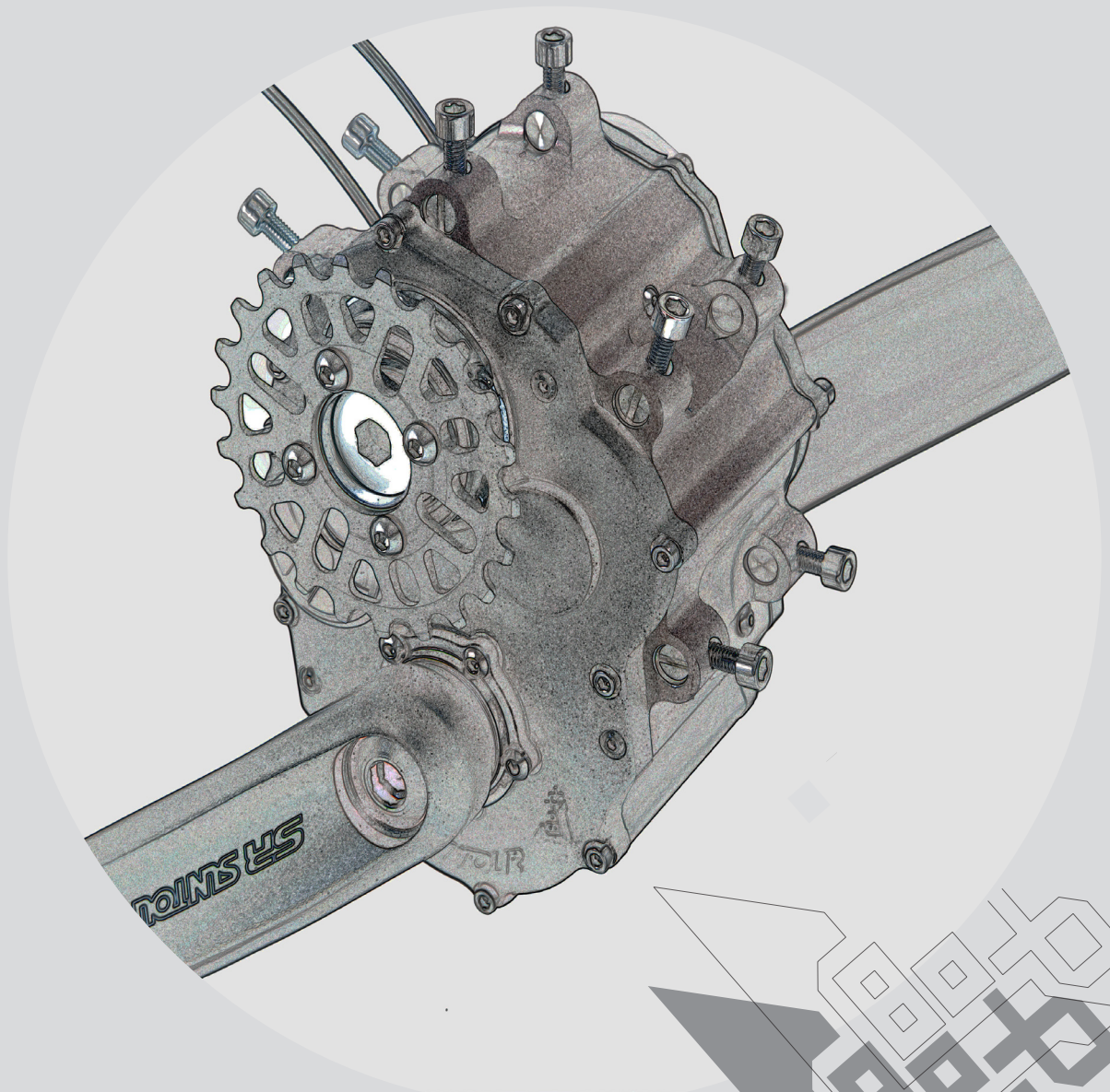
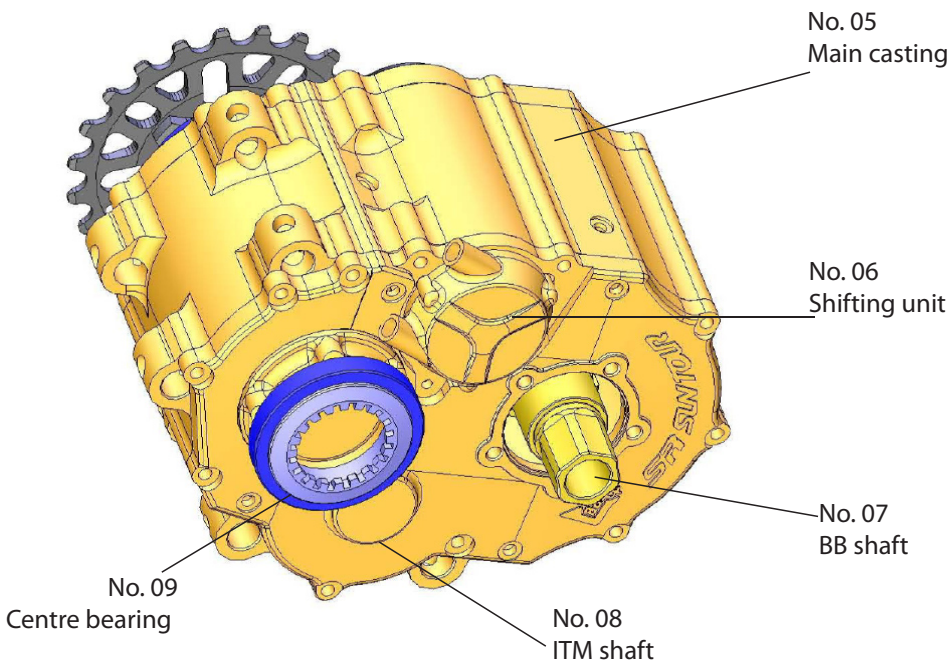
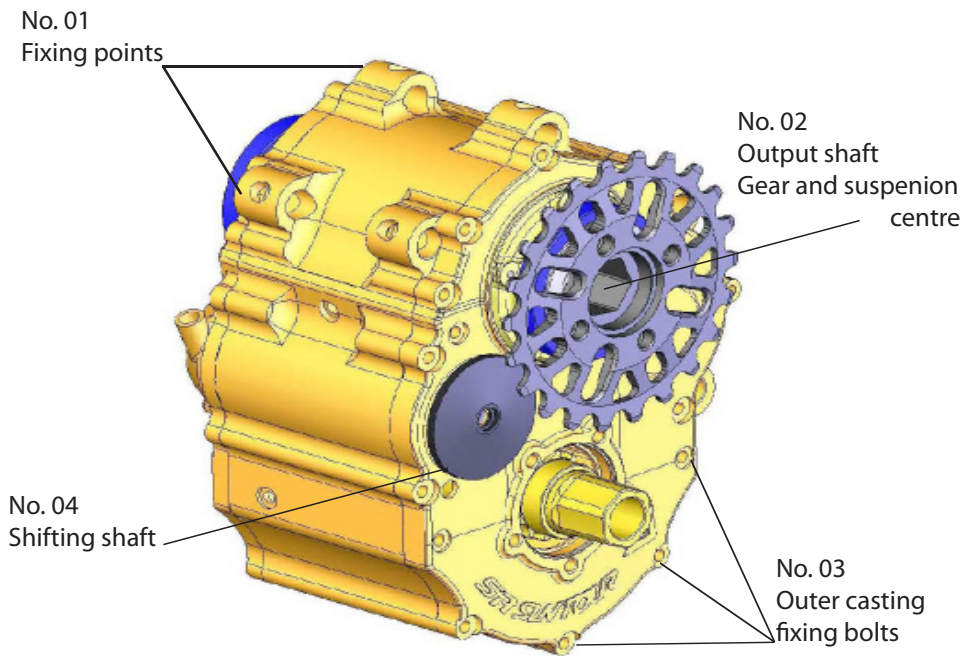

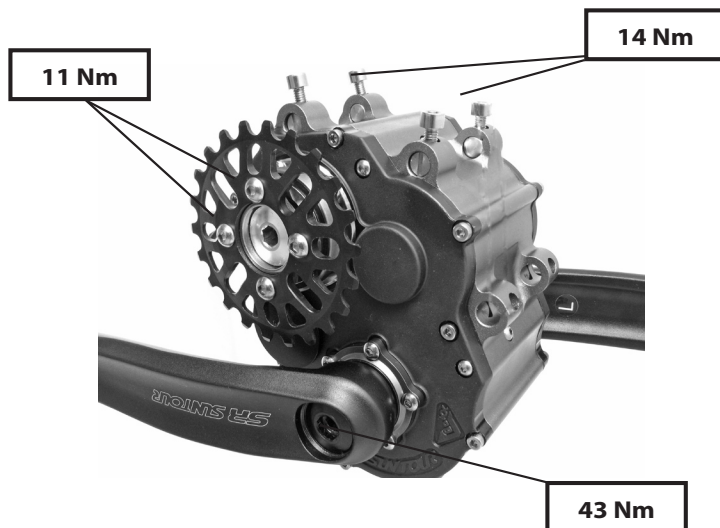

IMPORTANT SAFETY INFORMATION



WARNING !

Failure to comply with the given warnings and instructions may cause damage to the product, injuries or even death to the rider.

- ▶ Be sure to read this manual carefully before using your V-BOXX. Inappropriate usage of your V-BOXX may cause damage to the product, serious injuries or even death to the rider.
- ▶ Please note that only certified V-BOXX mechanics are allowed to open, repair, disassemble or reassemble the V-BOXX. Not following this instruction will void the warranty of your SR SUNTOUR V-BOXX.
- ▶ Only use genuine SR SUNTOUR parts. The use of aftermarket replacement and spare parts voids the warranty of your fork and might cause failure to the fork. This could result into an accident, injury or even death.
- ▶ This instruction sheet contains important information about the service and maintenance of your V-BOXX. Nevertheless please be informed that special knowledge and tools are essential to service and maintain the SR SUNTOUR V-BOXX. Common mechanical knowledge may not be sufficient to service or maintain the V-BOXX. Therefore we strongly recommend getting your V-BOXX installed, serviced and/or maintained by a trained and qualified bicycle mechanic. Improper installation, service or maintenance can result in failure of the product, accident, injury or even death.
- ▶ Always be equipped with proper safety gear. This includes a properly fitted and fastened helmet. According to your riding style you should use additional safety protection. Make sure your equipment is in flawless condition.
- ▶ Study all other owner's manuals provided with your bike and make yourself familiar with the components mounted to your bike.

GENERAL INFORMATION ON THE X-OFF Vboxx

The Vboxx system is based on a spline system with three shafts. Inside the Vboxx there are four clutches which are taking care of the gear switching operations.

- ▶ When you are changing gears you have to make sure that the grip shift lever is properly engaged. If the grip shift lever is placed in between two gear the clutches inside the box will not work properly. This will cause the gears to slip through and fear the risk that the internals of the box are getting damaged.
- ▶ Please note that you should avoid shifting under load. The internals of your Vboxx were not constructed for shifting actions under load. Shifting under load fears the risk that the clutches inside the V-BOXX are getting damaged.
- ▶ When you are shifting you should decrease the load on the V-BOXX. If you are shifting under load the tension of the shifting cable is too high. As a result of this the shifter can not be turned. Please do not use any force to try to shift under load.
- ▶ The gear box is a closed and sealed system. Therefore the gearbox itself is almost maintenance free. Please do not try to open the gearbox by yourself. This will void the warranty of your gearbox. Only certified V-BOXX mechanics are allowed to open the gear box. If there is any problem with it, please contact your local dealer for assistance or get in contact with one of the V-BOXX SERVICE CENTERS.
- ▶ Your dealer might not be allowed/able to repair or maintain the V-BOXX. Therefore we set up „Vboxx Service Centers“. For more detailed information please refer to the „SR SUNTOUR SERVICE CENTER“ section of this manual.
- ▶ Even your V-BOXX casting looks very stable you should avoid sliding over rocks. The main casting (No. 05) was produced through an extrusion method and is made of Alloy. When sliding over or hitting rocks it might get damaged.
- ▶ While shifting it can happen that you hear some kind of metallic noises coming from the box. This is mainly caused by the clutches and is not unusual.
- ▶ When riding in specific gears it may happen that you can hear some kind of „clip-clop“ noises coming from the box. This is caused by the clutches which are skipping over and nothing you should worry about.

GEAR SYSTEM

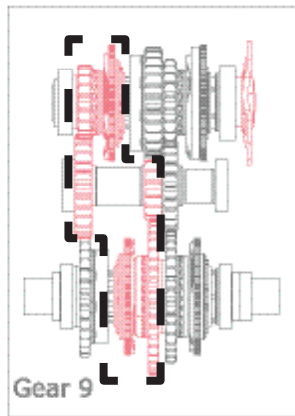
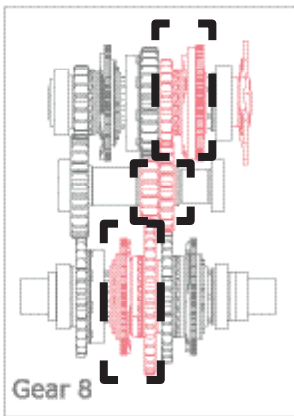
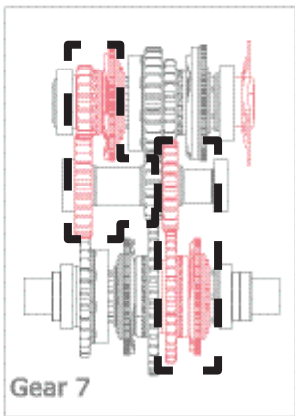
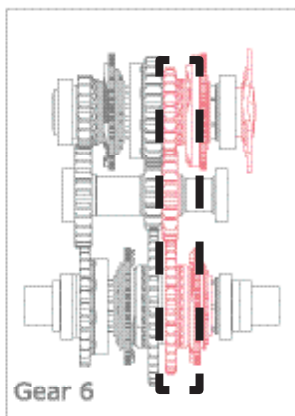
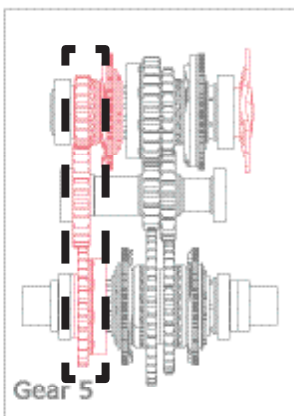
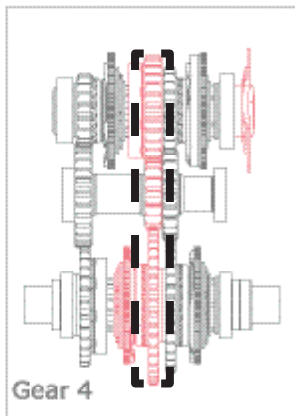
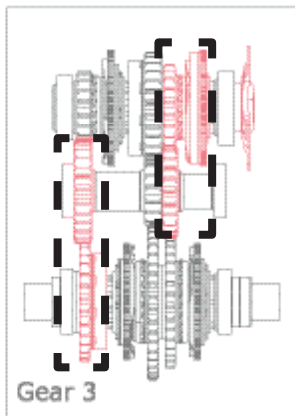
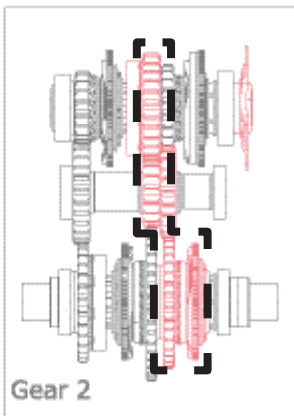
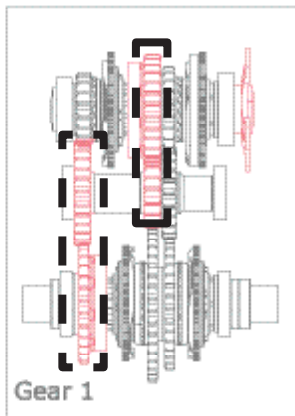

HOW TO CHANGE THE V-BOXX SHIFTING CABLES

After you have disassembled the shifters off your handlebar you have to put the shifter to gear No. 1

PUT TO GEAR 1



Take off the shifting unit (No. 9 page 1) using a 2.5mm Allen key.



2.5 mm



Take off the shifting unit (No. 9 page 1) using a 3mm Allen key.



3 mm



Detach the shifting unit off the boxx.

TAKE OFF

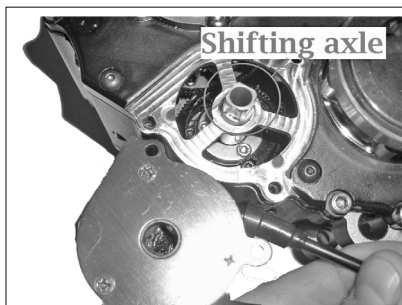

It might be helpful to mark the position of the square. When you are going to reassemble the shifting unit it indicates the correct position of the square. Use a screwdriver to draw this line.

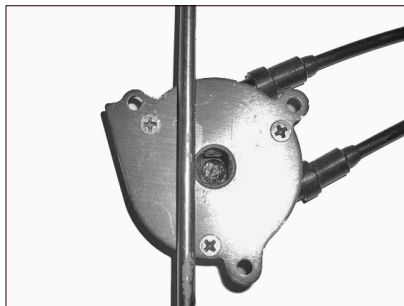

Take off the backside plate by using a Phillips screwdriver No.2.

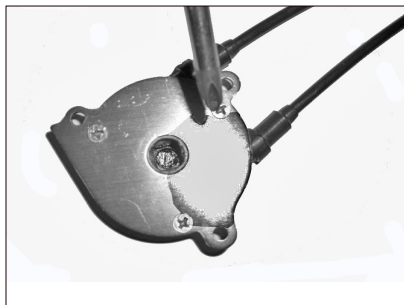

Unfasten the fixing bolts which are fixing the shifting cables by using a 3mm Allen key.

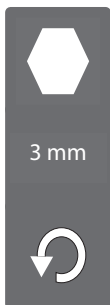

Take off the cover plate by using a Phillips screwdriver No. 2



In order to pull out the shifting cables you have to put the shifter to gear No. 3.....

GEAR 3



.....and gear No. 7

GEAR 7



Make sure to install the new shifting cables in the correct position.

WRONG

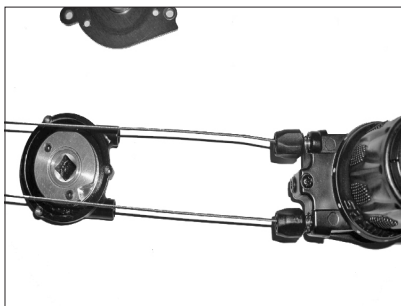

Make sure to install the new shifting cables in the correct position.

CORRECT

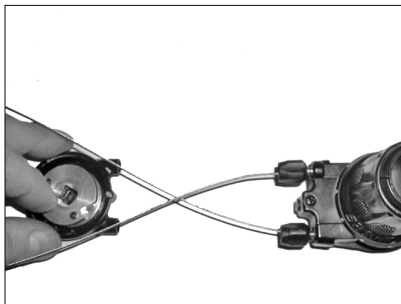

Put the shifter to position 1. Bring the cable in at shifting position No. 3. Run the cable through the casing into the shifting unit. Bring the cable almost one tour around the cable ring. Pull the cable hard and tighten the fixing bolts using a 2.5mm Allen key.

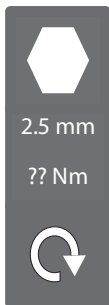

Turn the shifter to position No. 9 and bring the cable in. Run the cable through the casing into the shifting unit. Bring the cable almost one tour around the cable ring. Pull the cable hard and tighten the fixing bolt using a 2.5mm Allen key. Afterwards cut both cables to a proper length and turn the shifter back to position No.1.

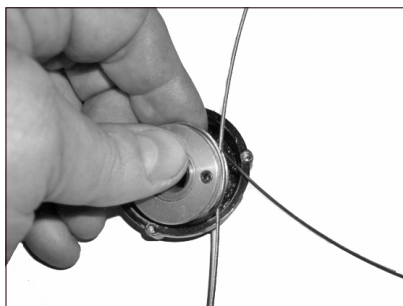
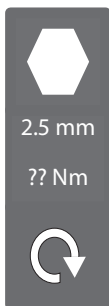

Reinstall the backside plate by using a Phillips screwdriver No.2.

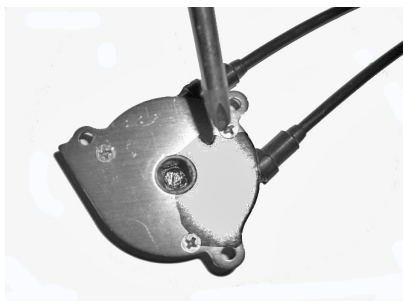

Check if the tension of the shifting cables is adequate. If the tension is too high the shifting will become too hard. Pull the cables slightly. You should have 1-2mm space on both sides.

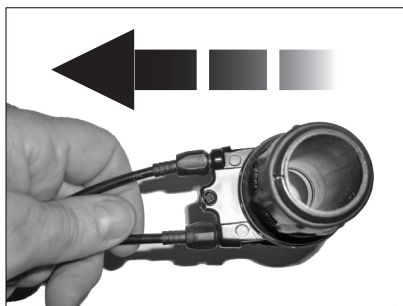

As already mentioned, the square has to be in the same position like it was before, when you were disassembling the shifting unit. If it is not anymore, you have to turn the shifting shaft counter clockwise until the stopper. The shifter needs to be positioned at gear 1.

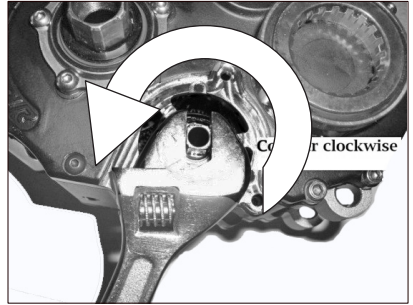

Reassemble the shifting unit back again using a 2.5mm Allen Key

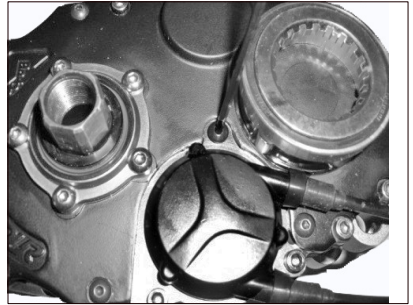
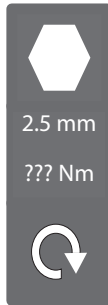

Reassemble the shifting unit back again using a 3mm Allen key.

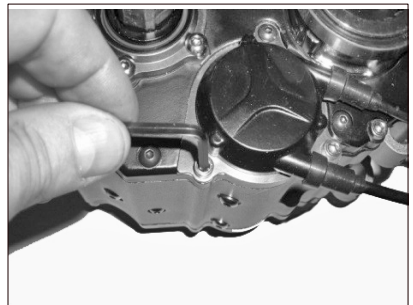
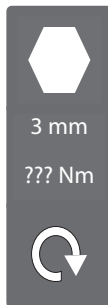

MAINTENANCE

Your SR SUNTOUR V-BOXX is a closed and sealed system, which means that the internals are protected against outside influence like moisture and dirt. Therefore the gearbox itself is almost maintenance free. Please do not try to open the gearbox by yourself. This will void the warranty of your gearbox. Only certified V-BOXX mechanics are allowed to open the V-BOXX. If there is any problem with it, please contact your local dealer for assistance or get directly in contact with one of the SR SUNTOUR V-BOXX SERVICE CENTER'S

Nevertheless, you should re-new the grease inside your V-BOXX once in a while to make sure the system runs nice and smoothly. Grease itself has the characteristic that it will get tough after some time of using. This is depending on three major facts, the time on the box riding, riding conditions and total duration. In general SR SUNTOUR recommends to change the grease within the V-Boxx every 8 month. If your are riding your bike every day you should re-new the grease more often. Also if your are riding in cold weather conditions the grease of your V-Boxx should be changed every 6 month.

Unscrew the „Upper Bolts“ . Pour clean gear box oil into the V-Boxx. We recommend to use oil with a lower viscosity. Reassemble the bolts again.



4 mm

??? Nm

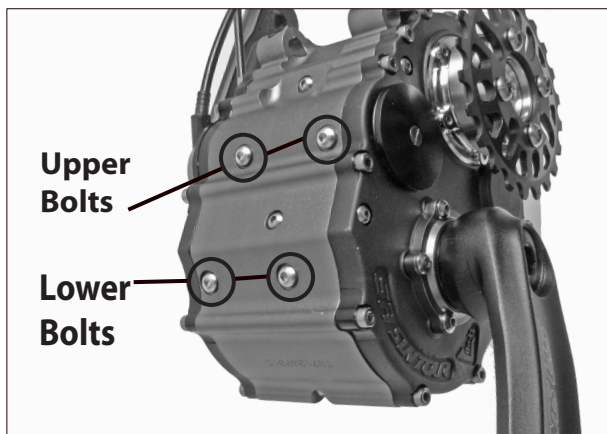

In order to wash the old grease away from the sprockets you should turn you crank several times.

TURN

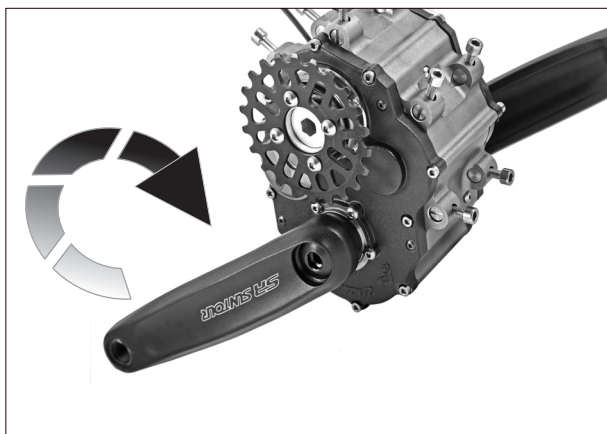

Unscrew the „Oil Release Bolt“ and drain the contaminated oil/grease out. Afterwards reassemble the bolt back again.

Please note that you can re-use the cleaning oil several times. Therefore keep it for next time.



4 mm

??? Nm

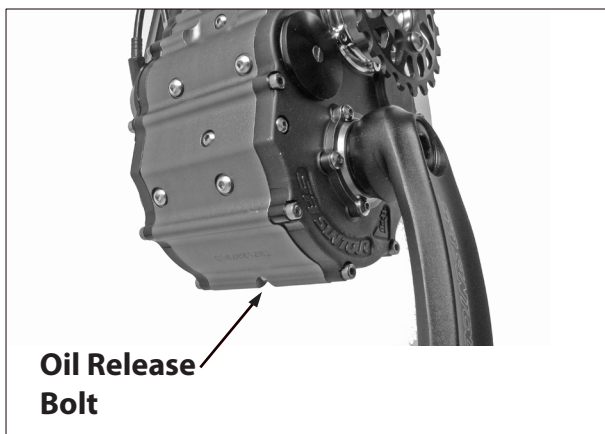

Unscrew the „Upper and Lower Bolts“. Press fresh grease through the holes onto the lower sprockets. You have to use grease with a lower viscosity, otherwise it get's to sticky. Turn your crank's in order to spread the grease on all other sprockets. Repeat this action until there is enough grease on all sprockets.



1.5mm

0.5 Nm

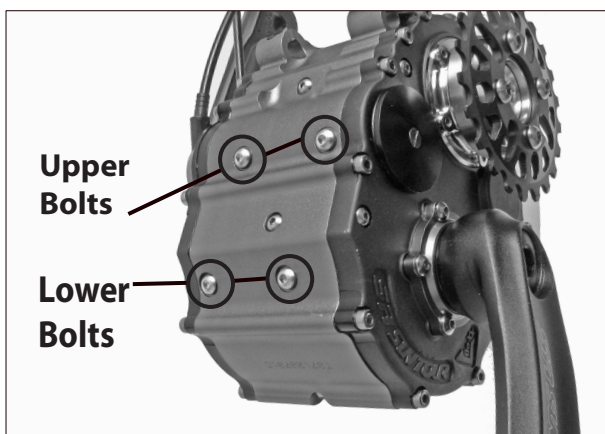

LIMITED WARRANTY

SR SUNTOUR warrants its products to be free from defects in material and workmanship under normal use for a period of two years from the date of original purchase. This warranty is made by SR SUNTOUR Inc. with only the original purchaser and is not transferable to any third party. Lodging a claim under this warranty must be made through the dealer where the bicycle or SR SUNTOUR product was purchased. To prove the original purchase the original retail invoice and a copy of your X-OFF V-BOXX FR9 Warranty Cards has to be provided.

LOCAL LAW:

This warranty gives you specific legal rights. According to the state (USA) or province (Canada) or every other country you are living in, you may have other rights than explained within these warranty regulations. These regulations shall be insofar adapted to the local law to be consistent with such law.

LIMITATION OF WARRANTY

This limited warranty does not apply to any defect of the product caused by improper installation, disassembling and re-assembling, intentional breakage, alterations or modification to the gear boxx, any unreasonable use or abuse of the product or any use for which this product was not intended for, accidents, crashes, improper maintenance, repairs improperly performed.

The obligation of this "Limited Warranty" is restricted to repairs and replacements of the V-BOXX or any parts of it in which there is a defect in materials or workman-ship within a period of two years.

SR SUNTOUR makes no express or implied warranties of fitness or merchatability of any kind, except as set forth above. Under no circumstances will SR SUNTOUR be liable for incidental or consequential damages.

Damages which are caused by the use of other manufacturer's replacements parts or damages which are caused by the use of parts that are not compatible or suitable to SR SUNTOUR V-BOXX are not covered by this warranty.

Within this manual you will find two „X-OFF V-BOXX FR9 Warranty Cards“. Send the card labeled with „Manufacturer“ back to SR SUNTOUR. Not sending back this card will void the warranty of your X-OFF V-BOXX FR9. For more detail information please check the „SR SUNTOUR SERVICE CENTER“ section of this manual.

This warranty does not apply to normal wear and tear.

WEAR AND TEAR PARTS:

- ▶ Dust Seals
- ▶ O-rings
- ▶ Rubber Moving Parts
- ▶ Stanchion Tubes

SR SUNTOUR V-BOXX SERICE CENTER'S

According to the complexity of the SR SUNTOUR V-BOXX, special technical knowledge is required to maintain or repair this product. Therefore we have set up special V-BOXX service centers around the globe to provide you with the best support we can give you, to make your V-BOXX work again. Whenever you have a problem with our V-BOXX, you should frist consultate your local dealer. All inquiries regarding V-BOXX services or repairs need to be done through your local dealer. The dealer should first get in contact with us by phone or email in order to clarify the situation. When sendind in your V-BOXX, you should always add a copy of your „X-OFF V-BOXX WARRANTY CARD“. Included in this manual there are two „warranty cards“. Please fill in both, for European countries please send the card which is labled as „MANUFACTURER“ back to the **V-BOXX Service Center Europe** .For the US and Canada please send it to the **V-BOXX Service Center USA&Canada**. For all other countries please send it back to the **V-Boxx Service Center Asia**. Please keep the „Owners“ version for your reference in a save place.

SR SUNTOUR V BOXX SERVICE CENTER**V-Boxx Service Center Asia**

SR SUNTOUR INC.

#7 Hsing Yeh Road, Fu Hsing Industrial Zone Chang Hua,
Taiwan, R.O.C.

Tel: 886- (0)4-769-5115

Fax: 886- (0)4-769-4028

E-mail: orders@srsuntour.com.tw

V- Boxx Service Center Europe

SR SUNTOUR EUROPE GmbH

Am Marschallfeld 6a 83626 Valley, Germany

Tel: 49-8024-3038152

Fax: 49-8024-4730984

E-mail: service@srsuntoureurope.com

V-Boxx Service Center France

SAV SR Suntour France (Service)

Z.A. Les Meres

F-38850 Chirens, France

TEL.: 33 (0) 9 65 02 00 00

FAX: 33 (0) 4 76 05 16 50

E-MAIL: arnaud@srsuntoureurope.com

V-Boxx Service Center USA & Canada

SR SUNTOUR USA

503 Columbia street, Vancouver, WA 98660, USA

Tel: 1-(0)360-737-6450

Fax: 1-(0)360-737-6452

E-Mail: service@usulcorp.com

LOCATION OF SERIAL NUMBER

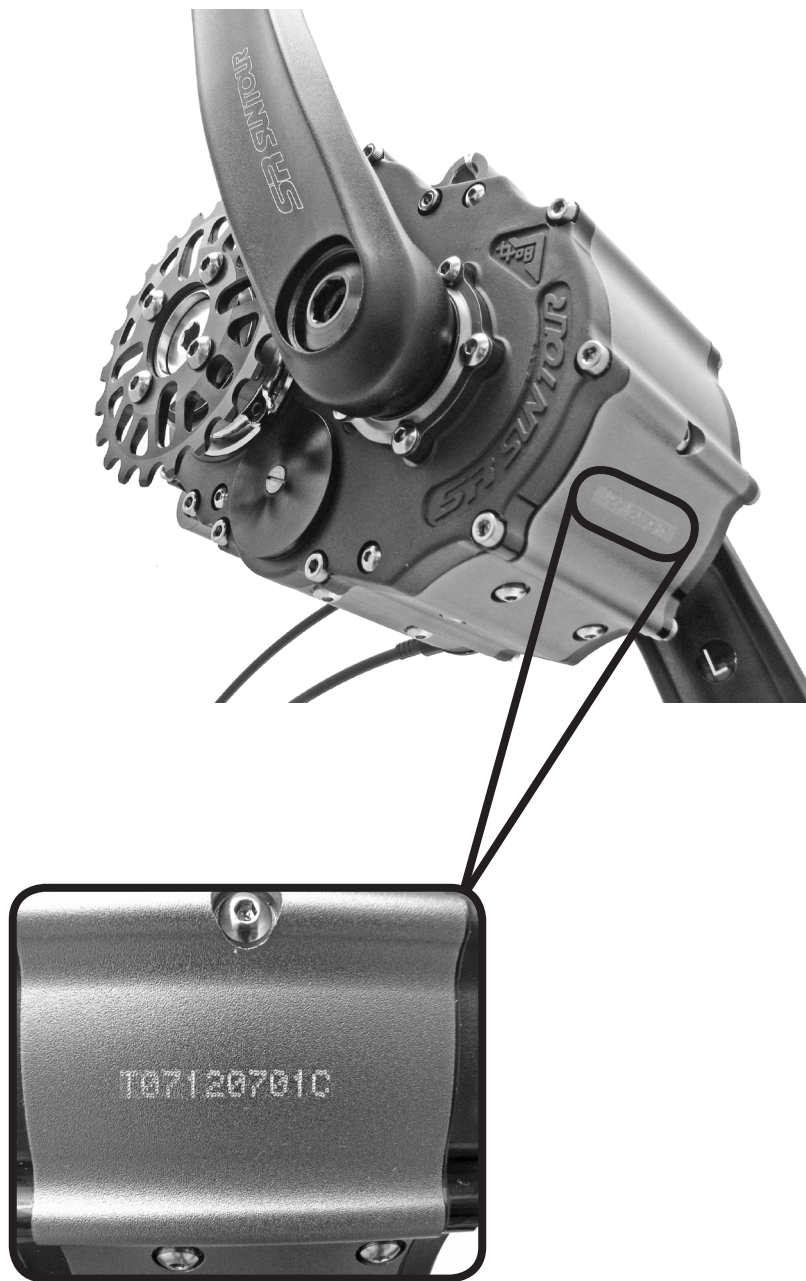

X-OFF V-BOXX FR9 WARRANTY CARD

OWNER

FIRST NAME

LAST NAME

STREET

ZIP CODE + CITY

EMAIL ADDRESS

PHONE NO.

BIKE MANUFACTURER

MODELL + YEAR

BOUGHT AT

BOUGHT ON

SERIAL NUMBER

X-OFF V-BOXX FR9 WARRANTY CARD

MANUFACTURER

FIRST NAME

LAST NAME

STREET

ZIP CODE + CITY

EMAIL ADDRESS

PHONE NO.

BIKE MANUFACTURER

MODELL + YEAR

BOUGHT AT

BOUGHT ON

SERIAL NUMBER

www.srsuntour-cycling.com
www.srsuntour-tuning-base.com

August 2008

SR SUNTOUR HEADQUATER

SR SUNTOUR INC.
#7 Hsing Yeh Rd
Fu Hsing Industrial Zone
Chang Hua
Twaiwan, R.O.C.
Tel.: +886 4 769115
Fax: +886 4 7694028
email: orders@srsuntour.com.tw

SR SUNTOUR EUROPE

SR SUNTOUR EUROPE GMB H
Am Marschallfeld 6a
83626 Valley
Germany
Tel.: +49 8024 3038152
Fax: +49 8024 4730984
email: service@srsuntoureurope.com

SR SUNTOUR USA

SR SUNTOUR USA
503 Columbia Street,
Vancouver, WA 98660
USA
Tel.: +1 (360) 737 6450
Fay: +1 (360) 60 737 6452
email: service@usulcorp.com